

**CBSE**  
**Class X Science**  
**Sample Paper 10**

**Time: 3 hrs**

**Total Marks: 80**

**General Instructions:**

- (i) The question paper comprises four sections A, B, C and D. There are 36 questions in the question paper. All questions are compulsory.
- (ii) Section–A - question no. 1 to 20 - all questions and parts thereof are of one mark each.
- (iii) These questions contain multiple choice questions (MCQs), very short answer questions and assertion - reason type questions. Answers to these should be given in one word or one sentence.
- (iv) Section–B - question no. 21 to 26 are short answer type questions, carrying 2 marks each. Answers to these questions should be in the range of 30 to 50 words.
- (v) Section–C - question no. 27 to 33 are short answer type questions, carrying 3 marks each. Answers to these questions should be in the range of 50 to 80 words.
- (vi) Section–D - question no. 34 to 36 are long answer type questions carrying 5 marks each. Answer to these questions should be in the range of 80 to 120 words.
- (vii) There is no overall choice. However, internal choices have been provided in some questions. A student has to attempt only one of the alternatives in such questions.
- (viii) Wherever necessary, neat and properly labelled diagrams should be drawn.

**SECTION A**

1. State the position of aluminium in the periodic table. (1)

**OR**

On what basis did Mendeleev arrange the element in his periodic table?

2. Define the term rancidity. (1)
3. Elements and their atomic numbers are given in the table below. (1)

Elements	P	Q	R	S
Atomic No.	6	24	32	49

Which of the elements belongs to the same group?

- i) P, Q
- ii) P, R
- iii) Q, R
- iv) Q, S



4. What is the current drawn by an electric bulb of 40 W when it is connected to 220 power supply? (1)
5. If 20 C of charge pass a point in a circuit in 1 s, what current is flowing? (1)
6. What is the nature of the image formed by a convex lens if the magnification produced by the lens is +3? (1)

**OR**

Which colour of light has the shorter wavelength- red or violet?

7. What is an electric current? (1)
8. Which effect of current is utilized in an electric light bulb? (1)
9. Name the scientist who discovered the magnetic effect of current. (1)

**OR**

If you hold a coil of wire next to magnet, no current will flow in the coil. What else is needed to induce a current?

10. Where does digestion of starch begin in human body? (1)
11. Name the structure through which pollen tube enters the ovule. (1)

**OR**

Which process takes place in the nucleus of a cell leading to variation in the offspring during reproduction?

12. Write one aquatic food chain. (1)

**OR**

Which of the following belong to the same trophic level: grasshopper, spider, grass, hawk and lizard?

13. During contraction of heart, what prevents the backflow of blood? (1)

**For question numbers 14, 15 and 16, two statements are given—one labelled Assertion (A) and the other labelled Reason (R). Select the correct answer to these questions from the codes (i), (ii), (iii) and (iv) as given below.**

- i) Both A and R are true, and R is the correct explanation of the assertion.  
ii) Both A and R are true, but R is not the correct explanation of the assertion.  
iii) A is true, but R is false.  
iv) A is false, but R is true.



**14.Assertion:** The blue colour of copper sulphate solution does not change when an iron nail is kept in its solution. (1)

**Reason:** Iron is more reactive than copper; hence, iron can displace copper.

**15.Assertion:** Mendel chose pea plant for his experiments. (1)

**Reason:** Pea plant provides diverse visible traits and has a short life span.

**OR**

**Assertion:** When TT and tt pea plant were crossed, only tall plants were obtained in F<sub>1</sub> progeny.

**Reason:** This was because tall allele was dominant over the short allele.

**16.Assertion:** The number of trophic levels are limited in a food chain. (1)

**Reason:** The flow of energy in a food chain is unidirectional.

**17. Read the following and answer any four questions from 17 (i) to 17 (v).** (1×4)

The growing size of the human population is a cause of concern for all people. The rate of birth in a given population will determine its size. Reproduction is the process by which organisms increase their population. The process of sexual maturation for reproduction is gradual and takes place while general body is still going on. Some degree of sexual maturation does not necessarily mean that mind or body is ready for sexual acts or for having and bringing up children. Various contraceptive devices are being used by human beings to control the size of population.

- i) Which of the following is a common sign of sexual maturation in both boys and girls?
  - a) Development of breasts
  - b) Growth of pubic hair
  - c) Adam's apple
  - d) Broadening of hips
- ii) Which of the following is an IUCD?
  - a) Copper-T
  - b) Diaphragm
  - c) Oral pill
  - d) Tubectomy
- iii) Which among the following is not a sexually transmitted disease?
  - a) Gonorrhoea
  - b) AIDS
  - c) Syphilis
  - d) Cholera

- iv) A couple wants to space the birth of their second child. Which of the following preventive measure could be taken by the husband?
- Oral pills
  - Diaphragms
  - Tubectomy
  - Condoms
- v) A pregnant woman visits the doctor to determine the sex of the child? Why is she denied of this testing?
- It is a complicated test.
  - It may result in female foeticide.
  - It is an expensive test.
  - It is harmful test for the developing foetus.

**18.** Read the following and answer any four questions from 18 (i) to 18 (v). (1×4)

When a strip of red-brown metal X is placed in a colourless salt solution  $YNO_3$ , metal Y is set free and a blue-coloured salt solution  $X(NO_3)_2$  is formed. The liberated metal Y forms a shining white deposit on the strip of metal X.

- What do you think metal X is?
  - Mercury
  - Copper
  - Gold
  - Zinc
- Name the salt  $YNO_3$ .
  - Mercury nitrate
  - Copper nitrate
  - Gold nitrate
  - Silver nitrate
- What could be metal Y?
  - Mercury
  - Copper
  - Gold
  - Silver
- Name the salt  $X(NO_3)_2$ .
  - Mercury nitrate
  - Copper nitrate
  - Gold nitrate
  - Zinc nitrate



- (v) What type of reaction takes place between metal X and salt solution  $\text{YNO}_3$ ?
- (a) Combination reaction
  - (b) Decomposition reaction
  - (c) Displacement reaction
  - (d) Redox reaction

19. Read the following and answer any four questions from 19 (i) to 19 (v) (1×4)

An object is placed at the following distances from a convex lens of focal length 15 cm:

- (a) 35 cm
- (b) 30 cm
- (c) 20 cm
- (d) 10 cm

Which position of the object will produce:

- i) a magnified real image?
  - a) 35 cm
  - b) 30 cm
  - c) 20 cm
  - d) 10 cm
- ii) a magnified virtual image?
  - a) 35 cm
  - b) 30 cm
  - c) 20 cm
  - d) 10 cm
- iii) a diminished real image?
  - a) 35 cm
  - b) 30 cm
  - c) 20 cm
  - d) 10 cm
- iv) an image of same size as the object?
  - a) 35 cm
  - b) 30 cm
  - c) 20 cm
  - d) 10 cm
- v) At what distance will the image be formed when an object is placed at 30 cm for this converging lens?
  - a) 10 cm
  - b) 20 cm
  - c) 25 cm
  - d) 30 cm



20. Read the following and answer any **four** questions from 20(i) to 20(v) (1×4)

Shama has a set of five substances. She has a chart stating resistivities of all the substances.

**Observe the table**

Substance	Resistivity
A	$1.6 \times 10^{-8} \Omega \text{ m}$
B	$44 \times 10^{-8} \Omega \text{ m}$
C	$2.63 \times 10^{-8} \Omega \text{ m}$
D	$2300 \Omega \text{ m}$
E	$10^{17} \Omega \text{ m}$

She has to choose an appropriate substance for performing electrical tasks. Which of the above substance according to you –

- i) Can be used as an insulator
  - a) A
  - b) B
  - c) B as well as C
  - d) E
- ii) Can be used for domestic wiring
  - a) A
  - b) B
  - c) A as well as C
  - d) D
- iii) Can be utilised in making solar cells and transistors
  - a) A
  - b) B
  - c) C
  - d) D
- iv) Is an alloy
  - a) A
  - b) B
  - c) C
  - d) E
- v) Behaves as a semiconductor
  - a) A
  - b) D
  - c) C
  - d) E

## SECTION B

21. Why is it said that sexual reproduction promotes diversity of characters in the offspring? (2)

OR

What is a clone? Why do offspring formed by asexual reproduction exhibit remarkable similarity?

22. What are villi? Mention their functions. (2)

23. From amongst the metals sodium, calcium, aluminium, copper and magnesium, name the metal: (2)

- (a) Which reacts with water only on boiling, and
- (b) Another which does not react even with steam.

OR

Name two metals which are used:

- (a) For making electric wires.
- (b) For making domestic utensils and factory equipment.

24. Name the scientists who gave the following laws in the early classification of elements: (2)  
(a) Law of octaves      (b) Law of triads

25. a) Name the colour of light which undergoes (i) more scattering and (ii) less scattering while passing through the atmosphere.  
b) Draw a ray diagram to show the formation of a rainbow. (2)

26. The circuit diagram given below shows the combination of three resistors  $R_1$ ,  $R_2$  and  $R_3$ : (2)

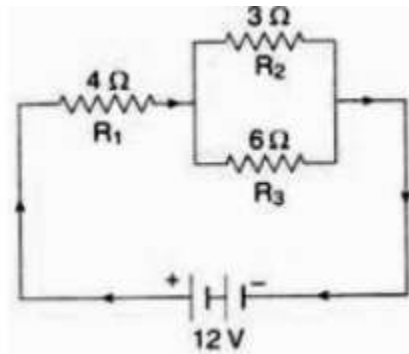

Find: (i) total resistance of the circuit.  
(ii) total current flowing in the circuit.

## SECTION C

27. You have visited a zoo where you have observed that a fish is respiring at a faster rate as compared to a dog. Explain the reason for this (3)

OR

What are the consequences of deficiency of haemoglobin in our body?

28. It is a well-known fact that a pregnant woman's health is the backbone of every family, society and thus nation. (3)

(a) Which tissue is responsible for providing nutrition from the mother to the growing embryo?

(b) According to you, what can be the likely measures to maintain a woman's health during pregnancy?

29. A cross was carried out between a pure-bred pea plant with axial flowers and a pure-bred pea plant with terminal flowers, and the  $F_1$  progeny was obtained. This progeny was selfed to obtain the  $F_2$  progeny. Answer the following questions: (3)

(a) What is the phenotype of the  $F_1$  progeny and why?

(b) Give the phenotypic ratio of the  $F_2$  progeny.

(c) Why is the  $F_2$  progeny different from the  $F_1$  progeny? (3)

30. Element 'X' belongs to Period 3 and Group 13 of the modern periodic table. (3)

(a) Determine the valence electrons and the valency of 'X'.

(b) Molecular formula of the compound formed when 'X' reacts with an element 'Y' (atomic number = 8).

(c) Write the name and formula of the compound formed when 'X' combines with chlorine.

31. (3)

(a) Name two constituents of baking powder.

(b) How does baking powder differ from baking soda?

(c) Explain the action of baking powder in the making of cake (or bread). Write the equation of the reaction involved.

32. Distinguish between ionic and covalent compounds under the following properties:

(i) Strength of forces between constituent elements (3)

(ii) Solubility of compounds in water

(iii) Electrical conduction in substances

33. How is an electric current produced using a magnetic field? Describe an experiment to show the magnetic field lines around a current-carrying circular coil. (3)





## SECTION D

34. Copy and complete the following table which relates to three homologous series of hydrocarbons: (5)

General Formula	$C_nH_{2n}$	$C_nH_{2n-2}$	$C_nH_{2n+2}$
IUPAC name of the homologous series			
Characteristics bond type			Single bonds
IUPAC name of the first member of the series			

**OR**

The molecules of alkene family are represented by a general formula  $C_nH_{2n}$ .

Answer the following:

- What do 'n' and '2n' signify?
- What is the name of alkene when  $n=4$ ?
- What is the molecular formula of alkene when  $n=4$ ?
- What is the molecular formula of the alkene if there are ten H atoms in it?
- Write the molecular formula of lower and higher homologous of an alkene which contains four carbon atoms.

35. Describe the structure and functioning of nephron. (5)

**OR**

Describe double circulation in human beings. Why it is necessary?

36. What is meant by refraction of light? Define refractive index in terms of speed of light in air and speed of light in refracting medium.

One student measures the angle of refraction as  $25^\circ$  in medium A, and the other student measures the angle of refraction as  $23^\circ$  in the other medium B for the same angle of incidence  $40^\circ$ . Find the refractive index of both media. In which medium does light travel faster? (5)

**OR**

Draw the ray diagrams and state the nature of the image and its position when the object is placed

- beyond the centre of curvature in front of the concave mirror
- at infinity in front of the convex mirror

(5)



**CBSE**  
**Class X Science**  
**Sample Paper 10 - Solution**

**Time: 3 hrs**

**Total Marks: 80**

---

**SECTION A**

1. Position in the Periodic Table: Period 3, Group IIIA(13)

**OR**

Mendeleev arrange the element in his periodic table on the basis of atomic masses.

2. Oils and fats react with oxygen and become oxidised or turn rancid. This process is called rancidity.
3. ii) Elements P and R both belong to Group 14 of the modern periodic table. They have the same valence electrons, i.e. 4 electrons in their outermost shell.

4. 0.18 A

$$P = VI$$

$$I = 40/220 = 0.18 \text{ A}$$

5.  $Q = 20 \text{ C}$ ,  $t = 1 \text{ s}$

$$I = Q/t$$

$$\text{Thus, } I = 20/1 = 20 \text{ A}$$

6. The image will be virtual and erect, since the magnification has positive value.

**OR**

Violet

7. An electric current is a flow of electric charges (electrons) through a conductor.

8. Heating effect of electric current.

9. Hans Christian Oersted

**OR**

Relative motion between the coil and the magnet.

10. The digestion of starch begins inside the mouth.



11. The pollen tube enters the ovule through the stigma.

**OR**

DNA copying takes place in the nucleus of a cell leading to variation in the offspring during reproduction.

12. Phytoplankton → Zooplankton → Small fishes → Large fishes

**OR**

Grasshopper and spider belong to the same trophic level.

13. During contraction of heart, the valves prevent the backflow of blood.

14. (iv) The assertion is false, but the reason is true. Iron is more reactive than copper; hence, it displaces copper to form ferrous sulphate.

15. (i) Both assertion and reason are true, and reason is the correct explanation of the assertion. Pea plants have visible contrasting characters and can be propagated easily in a short time.

**OR**

(i) Both assertion and reason are true, and reason is the correct explanation of the assertion. With respect to the height of the stem, tallness is a dominant trait over dwarfness which becomes recessive.

16. (ii) Both assertion and reason are true, but reason is not the correct explanation of the assertion. The number of trophic levels are limited in a food chain due to decrease in the level of energy at each trophic level.

17.

(i) b) Growth of pubic hair is observed in both boys and girls during sexual maturation.

(ii) a) Copper-T is an IUCD.

(iii) d) Cholera spreads through contaminated water.

(iv) d) Husband can make use of condoms to prevent the sperms from coming in contact with the egg.

(v) b) If the couple comes to know about the sex of the child, it may increase the chances of female foeticide as well.

18.

(i) (b) Copper

(ii) (d) Silver nitrate

(iii) (d) Silver

(iv) (b) Copper nitrate

(v) (c) Displacement reaction



19. Here,  $f=15\text{cm}$  and  $2f=30\text{cm}$

i) c) 20 cm

Because a magnified real image is formed when the object is placed between  $f$  and  $2f$

ii) d) 10cm

Because a magnified virtual image is formed when the object is placed between  $f$  and the lens

iii) a) 35cm

Because a diminished real image is formed when the object is placed beyond  $2f$

iv) b) 30cm

Because an image of same size as the object is formed when the object is placed at  $2f$

v) d) 30 cm

When an object is placed at  $2F$  of converging lens the image will be formed at  $2F'$  at right side of lens and image formed is real, inverted and of same size.

20.

(a) d) E

Substance E can be used as an insulator.

(b) c) A as well as C

Substances A and C can be used for the purpose of domestic wiring.

(c) d) D

Substance D can be used to make solar cells.

(d) b) B

An alloy has resistivity higher than a pure metal but lesser than a semiconductor. Thus, substance B is an alloy.

(e) b) D

Substance D is semiconductor.

## SECTION B

21. Sexual reproduction promotes diversity of characters in the offspring because sexual reproduction results from the fusion of two gametes coming from two different and sexually distinct individuals. This leads to variation which is necessary for evolution.

OR

Clone is an organism which is genetically identical with its parents.

In asexual reproduction, no new combination of genes takes place. The parental set of genes is distributed in the offspring. Hence, offspring formed by asexual reproduction exhibit remarkable similarity.



22. The small intestine has millions of tiny finger-like projections called villi. These villi increase the surface area for more efficient food absorption. Within these villi, are present numerous blood vessels that absorb the digested food and carry it to the bloodstream. It is hence from the bloodstream, the absorbed food is delivered to each and every cell of the body.

23.

(a) Aluminium.

(b) Copper.

OR

(a) Aluminium and copper.

(b) Copper and aluminium.

24.

(a) Newlands.

(b) Dobereiner.

25. While passing through atmosphere

(i) Blue light undergoes more scattering, while

(ii) red light undergoes less scattering.

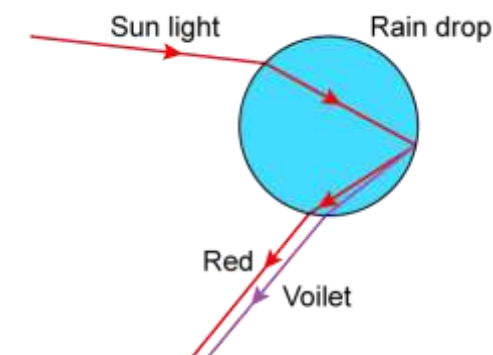

26.

(i) Total resistance of two resistors that are connected in parallel is

$$\frac{1}{R'} = \frac{1}{3} + \frac{1}{6}$$

$$\frac{1}{R'} = \frac{3}{6}$$

$$R' = 2 \Omega$$

$$\text{Total resistance of the circuit} = 2 + 4 = 6 \Omega$$

(ii) Total current flowing through the circuit =  $V/\text{total resistance}$

$$I = \frac{12}{6} = 2 \text{ A}$$



## SECTION C

27. Fish is an aquatic animal, while dog is a terrestrial animal. Aquatic organisms obtain oxygen dissolved in water, while terrestrial organisms use oxygen present in the air for respiration. As compared to air, the availability of oxygen in water is low. Hence, aquatic organisms like fish have to breathe faster as compared to terrestrial organisms like dog. A faster rate of breathing provides more oxygen to aquatic animals.

OR

Deficiency of haemoglobin in our body results in a condition called anaemia. In anaemia, the blood is unable to transport sufficient amount of oxygen required by the body. As a result, respiration will be less, and hence, less energy will be available for the body. A haemoglobin-deficient person will feel weak, pale, lethargic and will not be able to do heavy physical work.

28.

(a) The placenta is responsible for providing nutrition from the mother to the growing embryo. Exchange of nutrients, oxygen and waste products between the embryo and the mother takes place through the placenta.

(b) Measures a woman can take to maintain health during pregnancy:

- Consume a balanced diet
- Take food or medicinal supplements as required
- Be careful about diet and hygiene
- Exercise regularly
- Stop bad habits like smoking and drinking alcohol
- Take adequate rest

29. A pea plant with axial flowers (AA; dominant) was crossed with a pea plant with terminal flowers (aa, recessive). All the F<sub>1</sub> progeny would bear axial flowers because the trait for axial flowers is dominant over the trait for terminal flowers.

In the F<sub>2</sub> generation,

Parents → Aa × Aa

Gametes → A, a A, a

	A	a
A	AA (Axial)	Aa (Axial)
a	Aa (Axial)	aa (Terminal)

Phenotypic ratio → Axial : Terminal = 3 : 1

F<sub>1</sub> plants are heterozygous (Aa), and hence, only the dominant trait is visible in the F<sub>1</sub> generation. In the F<sub>2</sub> generation, factors responsible for the two traits are segregated and recombined to form a homozygous recessive trait for terminal flowers (aa).



**30.** Period of X = 3

Group of X = 13

Atomic number of X = 13

Electronic configuration: 2, 8, 3

(a) Number of valence electrons = 3 and valency = 3

(b) Atomic number of Y = 8

Electronic configuration = 2, 6

Valency of Y = 2

Molecular formula of the compound formed when 'X' reacts with an element 'Y' is  $X_2Y_3$ .

(c) Atomic number of Cl = 17

Electronic configuration = 2, 8, 7

Valency of Y = 1

Molecular formula of the compound formed when 'X' reacts with an element 'Y' is  $XCl_3$ .

**31.**

(a) Sodium hydrogen carbonate and tartaric acid.

(b) Baking powder is a mixture of baking soda and tartaric acid, whereas baking soda is only sodium hydrogen carbonate.

(c) When baking powder mixes with water, sodium hydrogen carbonate reacts with tartaric acid to evolve carbon dioxide gas which gets trapped in the wet dough and bubbles out slowly making the cake soft and spongy.

**32.**

(a) Ionic compounds have very strong inter-ionic attractive forces, whereas covalent compounds have comparatively weaker attractive forces between the constituent elements.

(b) Ionic compounds are soluble in water and not in organic solvents. Covalent compounds are insoluble in water and soluble in organic solvents. Some covalent compounds are soluble in water which can form H-bonding with water molecules.

(c) Ionic compounds conduct electricity as they dissociate into ions, while covalent compounds do not conduct electricity as they do not dissociate into ions. Graphite is an exception and can conduct electricity despite being covalent in nature.

**33.** Electric current is produced in a magnetic field by electromagnetic induction. When a conductor is moving in a magnetic field or if the magnetic field is changing around a fixed conductor, electric current is induced in the conductor.

Let us take a rectangular cardboard having two holes and insert a circular coil having a large number of turns through them, normal to the plane of the cardboard.



Let us connect the ends of the coil in series with a battery and key as shown in the figure. Sprinkle iron filings uniformly on the cardboard and plug the key.

Tap the cardboard gently a few times. We can see the pattern of iron filings which emerges on the cardboard. This pattern of iron filings indicates the magnetic field lines.

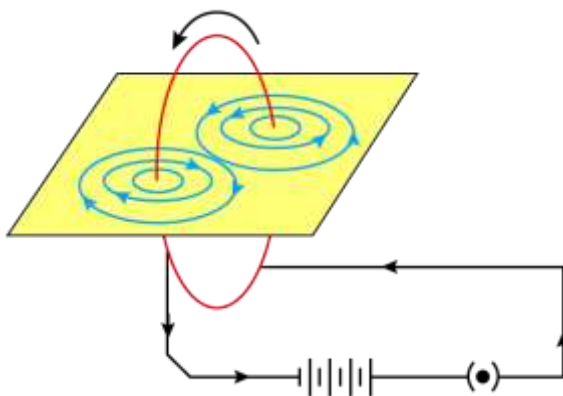

### SECTION D

34. The homologous series of hydrocarbons are:

General Formula	$C_nH_{2n}$	$C_nH_{2n-2}$	$C_nH_{2n+2}$
IUPAC name of the homologous series	Alkenes	Alkynes	Alkanes
Characteristics bond type	Double bond	Triple Bond	Single Bond
IUPAC name of the first member of the series	Ethene	Ethyne	Methane

OR

- 'n' signifies the number of carbon atoms and '2n' signifies the number of hydrogen atoms.
- The name of alkene when  $n=4$  is Butene.
- The molecular formula of alkene when  $n=4$  is  $C_4H_8$ .
- The molecular formula of alkene when there are 10 H atom in it  $C_5H_{10}$ .
- Lower homologous of alkene which contain four carbons is  $C_3H_6$ .  
Higher homologous of alkene which contain four carbons is  $C_5H_{10}$ .

35. Nephrons are structural and functional units of kidneys. They are long, coiled tubular structures. Each nephron shows the following parts - Malpighian body, proximal convoluted tubule, loop of Henle, distal convoluted tubule and collecting duct. The Malpighian body shows a cup-shaped Bowman's capsule, in which is present a tuft of capillaries called glomerulus.





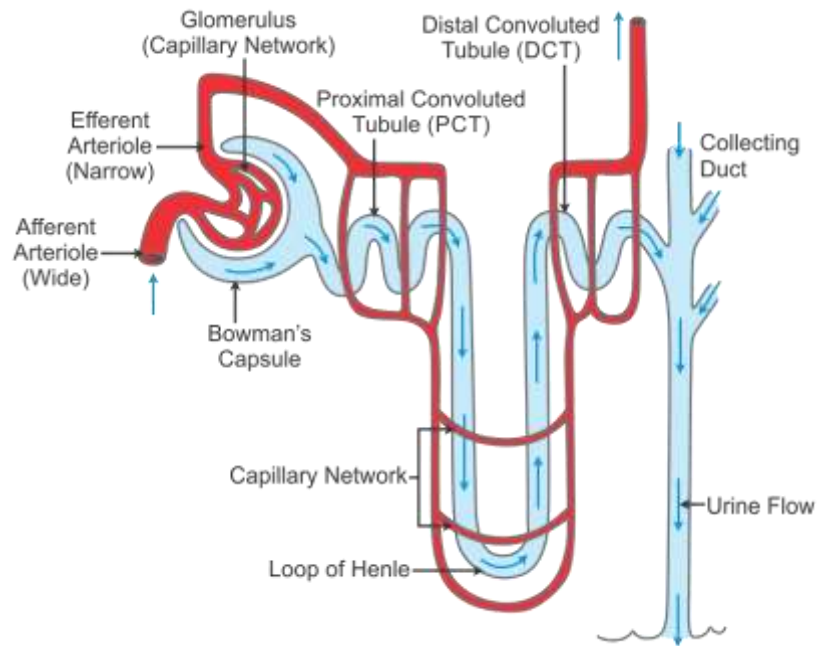

Glomerulus carries out filtration of blood under pressure. This process is called ultrafiltration. Nephrons are the basic filtration units in kidneys. They filter the blood and form and concentrate urine. Useful substances are reabsorbed by the nephrons and put back into circulation. The urine formed by all the nephrons is collected and then sent to the urinary bladder through the ureter.

**OR**

The heart receives deoxygenated blood from different parts of the body, and it pumps this blood to the lungs. The oxygenated blood from the lungs returns to the heart, which is pumped again into different parts of the body by the heart. Thus, the blood passes twice through the heart making one complete round through the body. This is called **double circulation**.

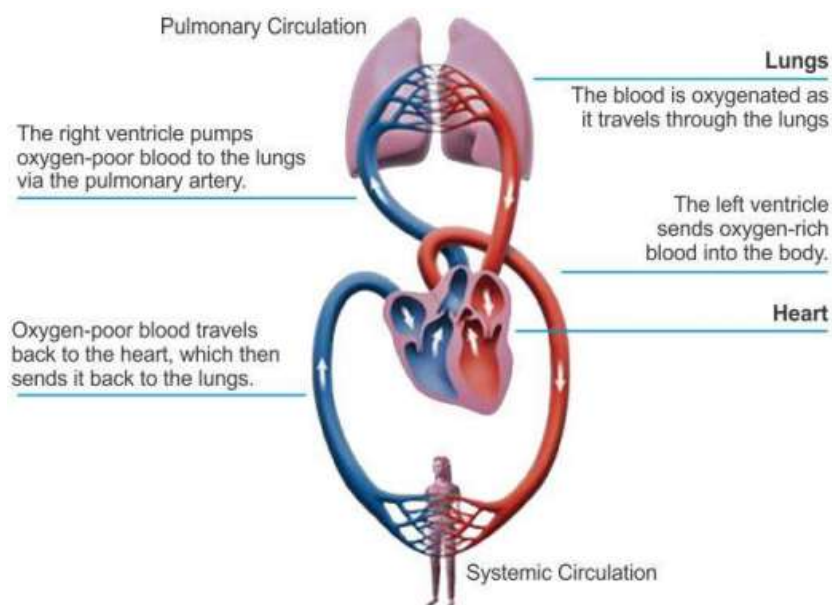

### Pulmonary and Systemic Circulation

The pulmonary circulation pertains to lungs. The blood flows from the right ventricle to the lungs. Pulmonary veins collect oxygenated blood from the lungs and carry it back to the heart (left auricle).

The systemic circulation pertains to the major circulation of the body. The aorta receives the blood from the left ventricle and sends it to the various parts of the body. Veins collect the deoxygenated blood from the body parts and pour it back into the right auricle.

36. When light travels from one transparent medium to another transparent medium, deviation of its path takes place at the boundary. When light rays enter from a rarer medium to a denser medium (e.g. air to glass), they deviate towards the normal drawn at the point of incidence on the boundary. When light rays emerge out of a denser medium to a rarer medium (e.g. glass to air), they deviate away from the normal drawn at the point of incidence on the boundary. This is known as refraction of light.

In medium A: Refractive index  $\mu_A = \sin(40^\circ)/\sin(25^\circ) = 1.521$

In medium B: Refractive index  $\mu_B = \sin(40^\circ)/\sin(23^\circ) = 1.645$

$$\text{Refractive index } \mu \text{ of a medium} = \frac{c}{v} = \frac{\text{Velocity in air}}{\text{Velocity in medium}}$$

Hence, velocity in a medium is inversely proportional to the refractive index. So, light travels faster in medium A compared to medium B.

**OR**

- (a) Object placed beyond the centre of curvature in front of a concave mirror:

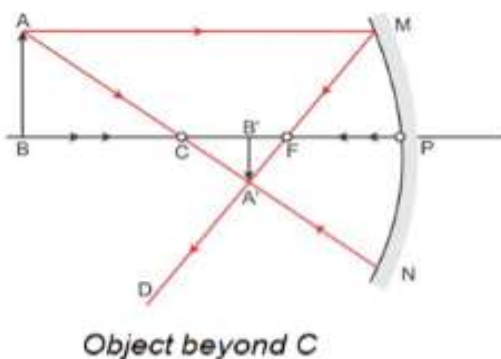

Position of object	Position of image	Size of image	Nature of image
Beyond C	Between F and C	Diminished	Real and inverted



(b) Object placed at infinity in front of a convex mirror:

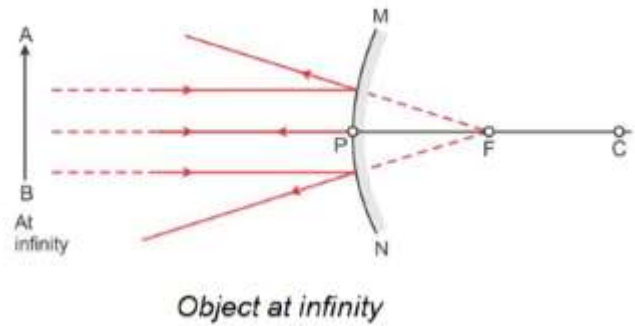

Position of object	Position of image	Size of image	Nature of image
At infinity	At focus F behind the mirror	Highly diminished, point sized	Virtual and erect